



Village of Ballston Spa Roofs Historic District Design Guidelines

Roofs are an important character-defining feature of a building. Roof shape, materials and details contribute to the historic character and significance; roof form and the pattern, scale, color and texture of roofing materials are important visual features of historic buildings. Not only is the roof a significant feature of a building, a weather-tight roof is key to the long-term preservation of the entire structure.

Roofs of historic buildings are typically hipped, gable, gambrel, pyramidal or a combination of gable and hipped. Typical roofing materials of the 19th and early 20th century were slate, metal, wood shingles or composition materials.

If roof repairs are needed, inspect to determine if active leaks are present and identify their source. Do not assume the roof material is at fault; gutters, valleys and flashings may be the cause. Also, "false leaks" can be caused by moisture condensation in the attic due to improper ventilation.

Roofs

- The original size, shape and pitch of the roof should be maintained.
- Altering the roofline should be avoided if it redefines the architectural style of the structure.
- Repair and maintain original roofing materials whenever possible.
- If replacement is necessary, the roof should match the original design, size, shape, material and texture or should be based on historic evidence. If no historic evidence is available, the roof should match in design and materials the architectural style and period of the historic building.
- The use of rolled roofing is discouraged except for flat roofs.
- The use of plastic, fiberglass and tar and gravel roofing materials is also discouraged on historic and contributing structures.
- The introduction of skylights, sun tunnels, vents or attic ventilators is to be avoided on visible street facades.

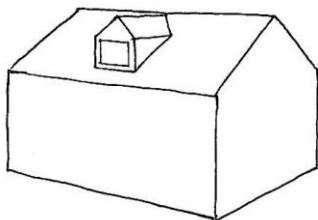

GABLED ROOF
W/ GABLED ROOF DORMER

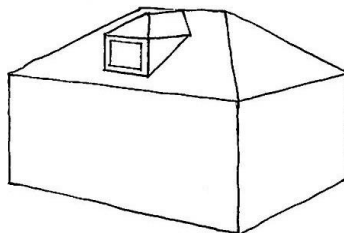

HIPPED ROOF
W/ HIPPED ROOF DORMER

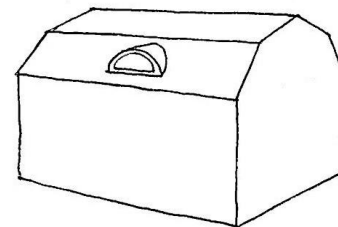

GAMBREL ROOF
W/ EYEBROW ROOF DORMER

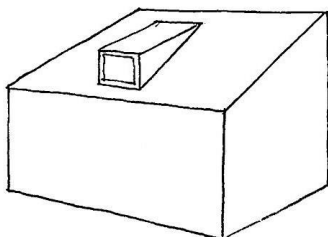

SHED ROOF
W/ SHED ROOF DORMER

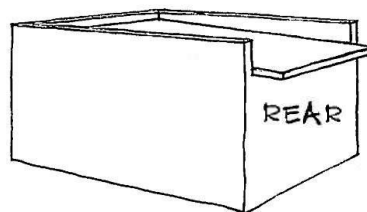

LOW PITCHED SHED ROOF
W/ PARAPET & OVERHANG

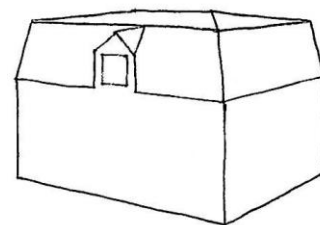

MANSARD ROOF
W/ GABLED WALL DORMER

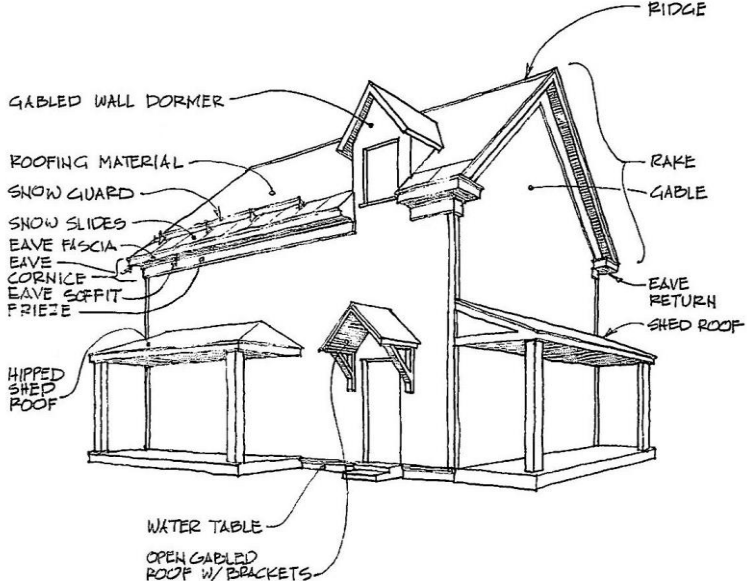

GABLED ROOF BUILDING

DETAILS

- Roof details, including eaves, cornice, gable-end trim and the entablature, should be maintained and preserved whenever possible as they contribute and define the architectural character of the structure.
- A building cornice acts as a sculptural "cap" with three-dimensional depth and shadows. Cornices should be prominent and scaled to visually balance the façade.

DORMERS

- Preserve and maintain the original size and shape of dormers particularly on the primary façade.
- New dormers should be reserved for the rear or less visible sides of the structure and be appropriate in scale and proportion.

SATELLITE DISHES & ALTERNATIVE ENERGY SYSTEMS

- Satellite dishes should be minimal in size. The addition of satellite dishes and alternative energy systems should be reserved for the rear or less visible sides of the structure
- No exterior woodwork or trim detail should be altered or damaged in the installation of these devices.

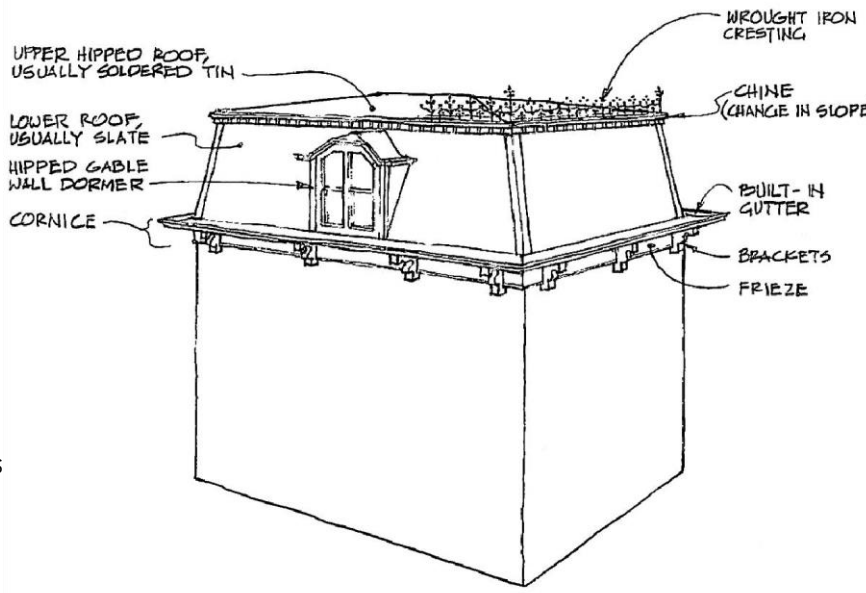

MANSARD ROOF BUILDING

STANDARD

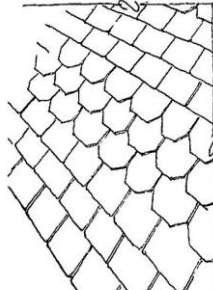

MIN. SLOPE 4:12

GRADUATED

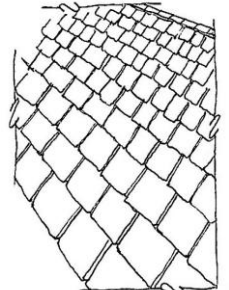

FROM EAVE TO RIDGE, EACH COURSE GETS NARROWER & SLATES ARE REDUCED IN LENGTH, WIDTH & THICKNESS

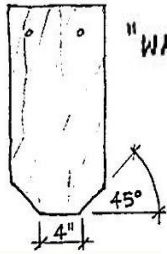

TYPICAL SLATE
9" X 18" X 1/4" THICK
"SQUARE END" SHOWN
7" TO WEATHER

SLATE ROOFING

METAL ROOFING

- New sheet metal roofs are encouraged to be ribbed or have a standing metal seam to break up the surface.

STANDING SEAM

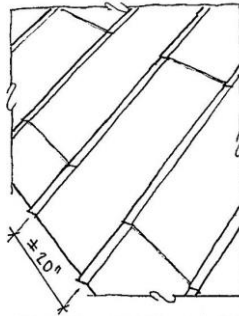

COPPER, PRE-PAINTED STEEL, STAINLESS, GALVANIZED STEEL, TIN
MIN. SLOPE 2 1/2 : 12

FLAT SEAM

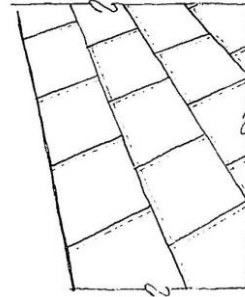

ROOFS OF SLIGHT PITCH, CURVED SURFACES
TIN, LEAD COATED COPPER, MONEL
SEAMS HAMMERED & SOLDERED
PITCH OF 1/2 : 12 OR LESS

CHIMNEYS & VENTS

- Chimneys are a visible character-defining feature of a house. Many have decorative features that substantially contribute to the overall design of the structure.
- Existing chimneys should be maintained. Removing a historic chimney in good repair is strongly discouraged.
- Any repairs should match the original in shape, material, and color. Finishing a chimney with cement/stucco parging should only occur if historically accurate.
- New chimneys should match the style and scale of the building.
- Penetrations for plumbing, HVAC mechanicals and stove/fireplace vents should be placed on less visible sides of the structure. These penetrations should relate in color and texture to the roofing material and/or flashing. Galvanized or aluminum penetrations are discouraged.

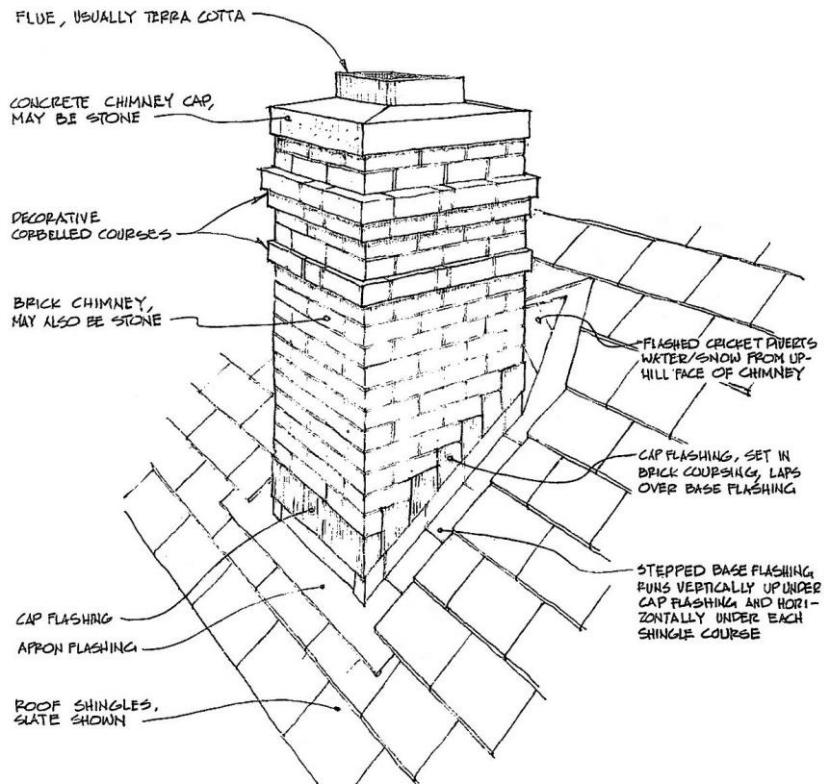

TYPICAL CHIMNEY INSTALLATION

STONE CAP OVER BRICK EXTENSIONS

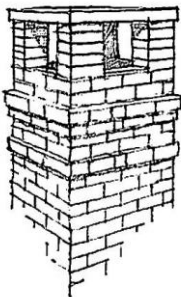

STONE CAP AND EXTENSIONS

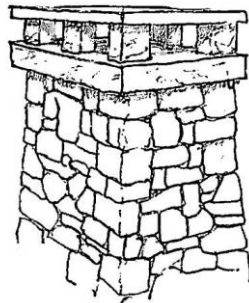

CHIMNEY POTS



ARCHED CAP

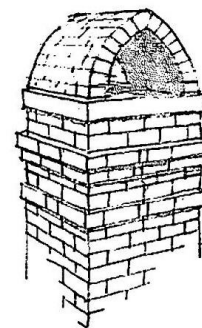

GUTTERS

- Original gutters and drainage features should be maintained whenever possible.
- If replacement is necessary, gutters and downspouts should be historically appropriate. The half-round form is historically appropriate for many 19th and early 20th century buildings.
- Gutters and downspouts are recommended to be painted a color to match the nearest surface (wood trim, brick, etc.).
- New gutters and downspouts should replicate historic materials. Vinyl is discouraged on historic and contributing structures.
- Replacing concealed, or built-in, gutters with exposed gutters is discouraged.

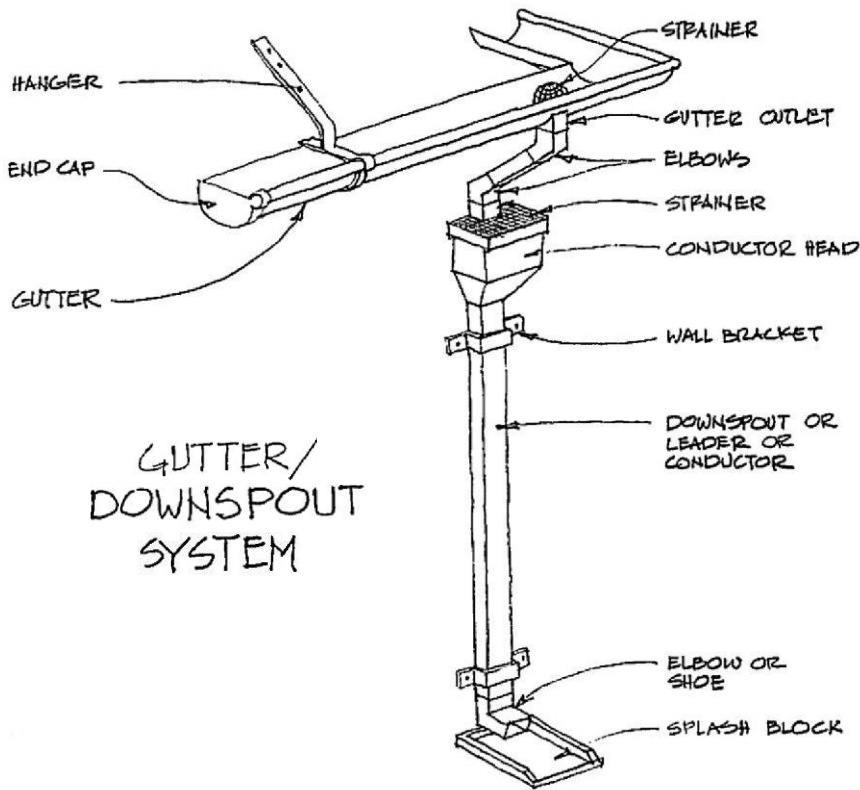

GUTTER/
DOWNSPOUT
SYSTEM

BUILT-IN GUTTER

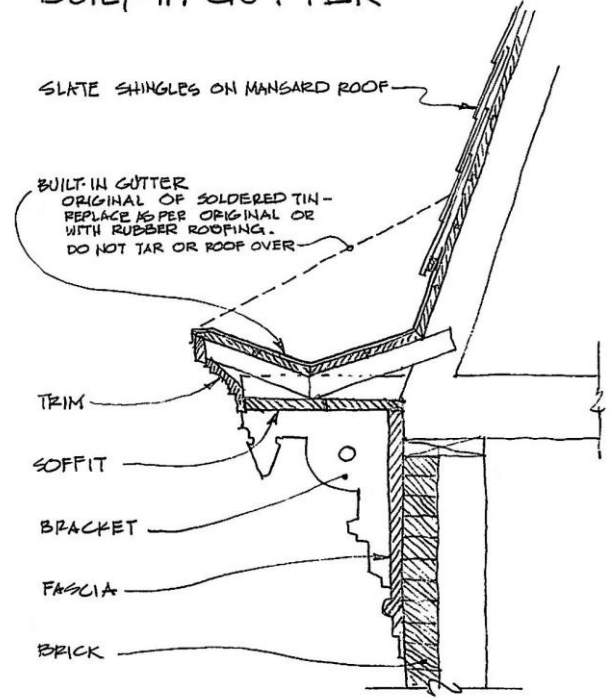

DOWNSPOUT SHAPES

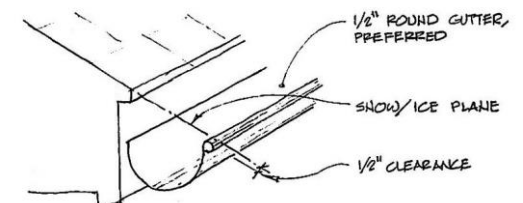
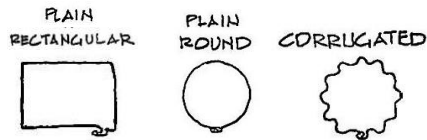

CONSIDERATIONS

- Replacing a roof with high quality materials will result in less long-term maintenance and replacement costs.
- When replacing a historic roof material, consider the life cycle and long-term return on the cost of the material. A slate roof may initially be more expensive but may last three to five times longer than a less expensive asphalt shingle roof.
- Recommended Resource, NPS Preservation brief: <https://www.nps.gov/orgs/1739/upload/preservation-brief-04-roofing.pdf>

Village of Ballston Spa
Historic District Commission
66 Front Street, (518) 885-5711

<http://www.villageofballstonspa.org/historic-district-commission>